

REV.	DESCRIPTION	DATE	DRAWN	APPROVED
A1	DWG.REL	2016/10/7	FANG	YANG

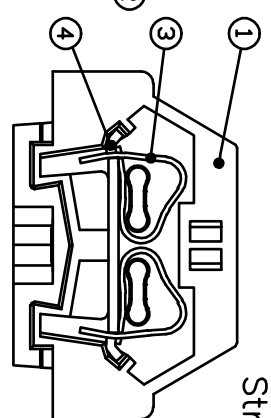
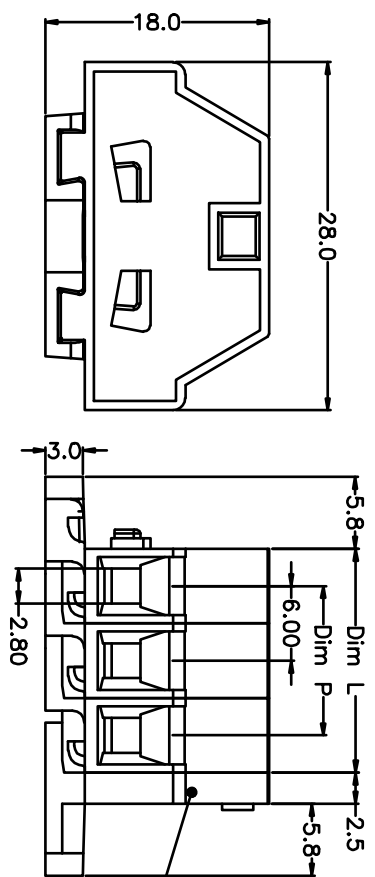
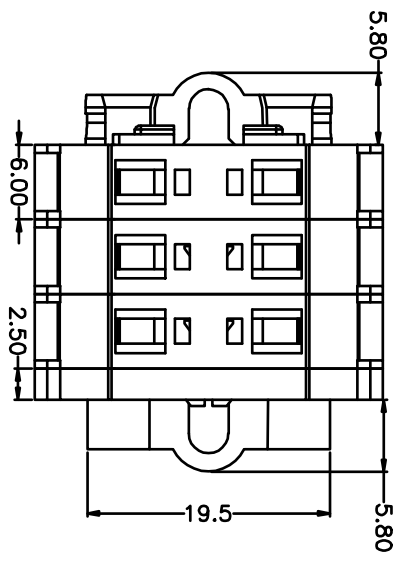

- Material
 - ①Housing : PA66, UL94V-0
 - ②Cover : PA66, UL94V-0
 - ③Reed : Stainless steel
 - ④Pin header : Brass, Tin plated

- Electrical

UL	IEC
Rated voltage : 300V	450V
Rated current : 15A	24A
Insulation resistance: 500MΩ/DC500V	
Withstanding Voltage : AC2500V/1min	
Wire range: 26-14AWG	2.5mm ²

- Mechanical
 - Operating temperature: -40°C ~ +105°C
 - Soldering temperature: 250°C ± 5 / 5sec
 - Strip length: 8-9mm

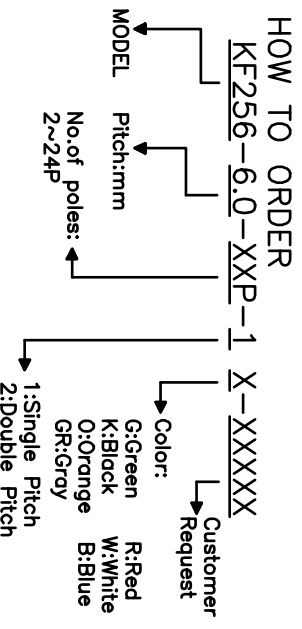

N=Number of Poles
 Dim P=(N-1)x6.00
 Dim L=Nx6.00

Poles	Dim P	Dim L
2-6P	±0.10	±0.15
7-12P	±0.20	±0.20
13-18P	±0.25	±0.30
19-24P	±0.30	±0.40

GENERAL TOLERANCE	ANGLE TOLERANCE
X: ±0.5	X: ±5'
.X: ±0.3	.X: ±3'
.XX: ±0.1	.XX: ±1'

DRAWING TYPE	CUSTOMER
SCALE	1:1
DRAWING NO.	XP0012016-xxxx

PROJECTION	TITLE
UNITS	mm
SHEET SIZE	A4
SERIES	KF256

凯峰电子有限公司
 CIXI KAIFENG ELECTRONIC CO.,LTD