

REV.	DESCRIPTION	DATE	DRAWN	APPROVED
A1	DWG.REL	2016/10/7	FANG	YANG

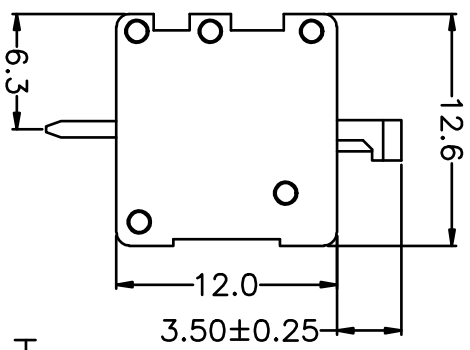
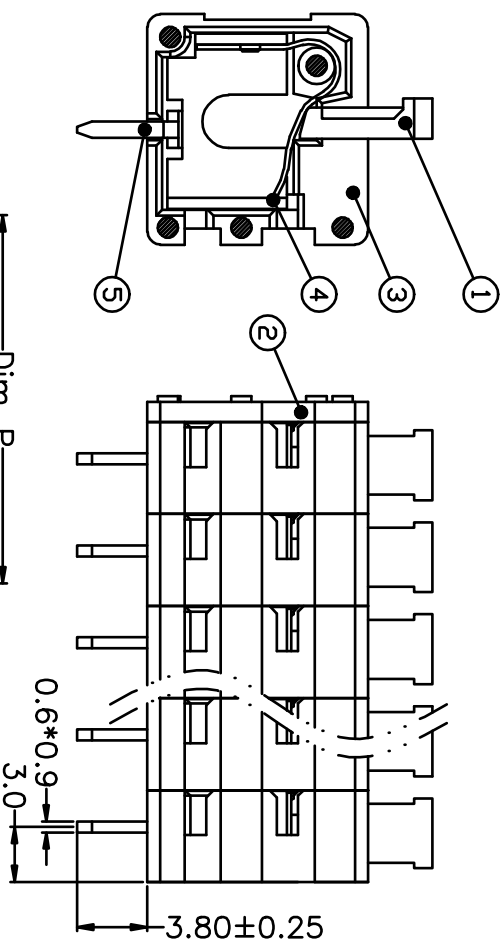
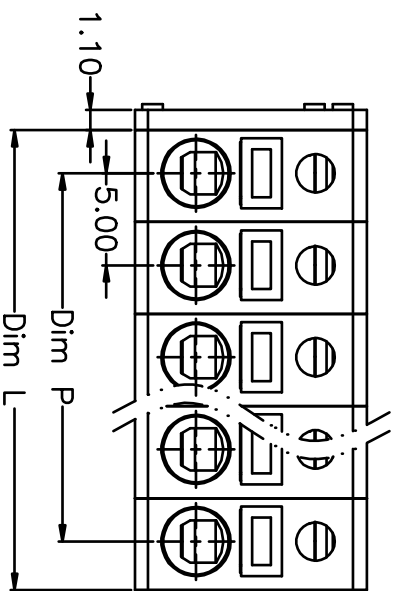

- Material
  - ØButton : PA66, UL94V-0
  - ØCover : PA66, UL94V-0
  - ØHousing : PA66, UL94V-0
  - ØReed : Stainless steel
  - ØPin header : Brass, Tin plated

- Electrical
 

UL	IEC
Rated voltage : 300V	250V
Rated current : 8A	10A
Insulation resistance: 500MΩ/DC500V	
Withstanding Voltage : AC2000V/1min	
Wire range: 26-16AWG	1.5mm <sup>2</sup>

- Mechanical
  - Operating temperature: -40°C ~ +105°C
  - Soldering temperature: 250°C ±5/5sec
  - Strip length: 8-9mm

HOW TO ORDER

KF246V-5.0-XXP-1 X-XXXX

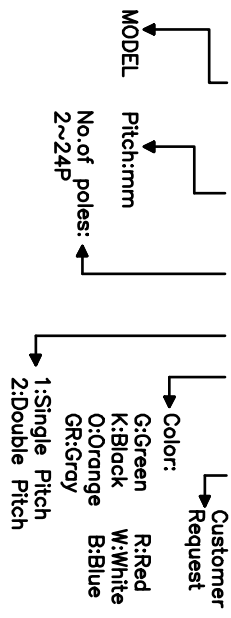

N=Number of Poles  
Dim P=(N-1)X5.00  
Dim L=Nx5.00

Poles	Dim P	Dim L
2-6P	±0.10	±0.15
7-12P	±0.20	±0.20
13-18P	±0.25	±0.30
19-24P	±0.30	±0.40

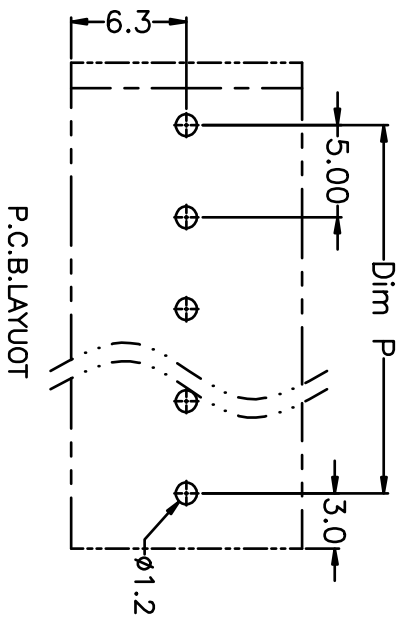

GENERAL TOLERANCE	ANGLE TOLERANCE
X: ±0.5	X: ±5°
.X: ±0.3	.X: ±3°
.XX: ±0.1	.XX: ±1°

DRAWING TYPE	CUSTOMER
SCALE	1:1
DRAWING NO.	XP0012016-xxxx

PROJECTION	TITLE
UNITS	KF246V-5.0-XXP
SHEET SIZE	A4
SERIES	KF246

**凯峰** 慈溪市凯峰电子有限公司  
KAIFENG ELECTRONIC CO.,LTD  
CIXI KAIFENG ELECTRONIC CO.,LTD