

REV.	DESCRIPTION	DATE	DRAWN	APPROVED
A1	DWG.REL	2016/10/7	FANG	YANG

- Material
 - ØButton : PA66, UL94V-0
 - ØCover : PA66, UL94V-0
 - ØHousing : PA66, UL94V-0
 - ØReed : Stainless steel
 - ØPin header : Brass, Tin plated

- Electrical

UL	IEC
Rated voltage : 300V	250V
Rated current : 10A	15A
Insulation resistance: 500MΩ/DC500V	
Withstanding Voltage : AC2000V/1min	
Wire range: 22-14AWG	1.5mm ²

- Mechanical
 - Operating temperature: -40℃ ~ +105℃
 - Soldering temperature: 250℃ ± 5 / 5sec
 - Strip length: 10mm

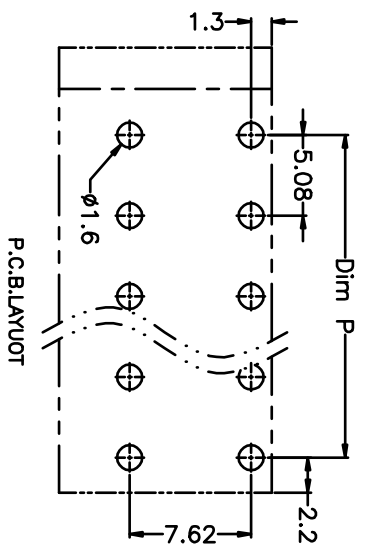
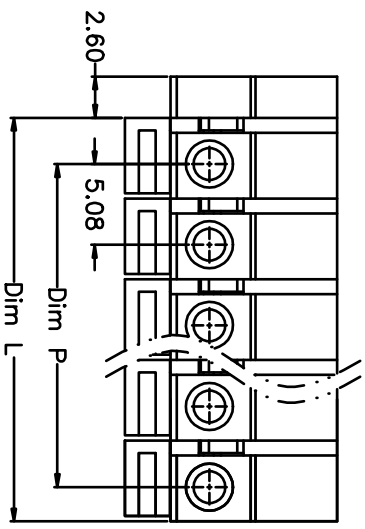
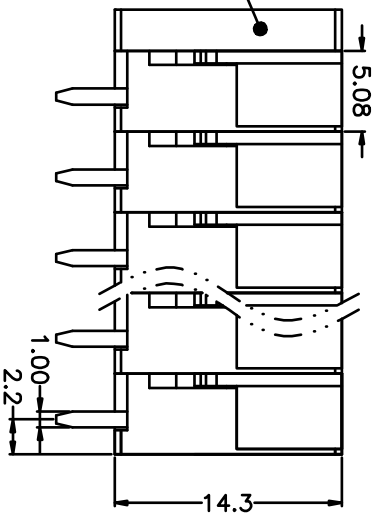
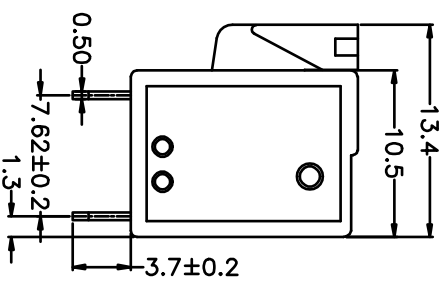

N=Number of Poles
 Dim P=(N-1)x5.08
 Dim L=Nx5.08

Poles	Dim P	Dim L
2-6P	±0.10	±0.15
7-12P	±0.20	±0.20
13-18P	±0.25	±0.30
19-24P	±0.30	±0.40

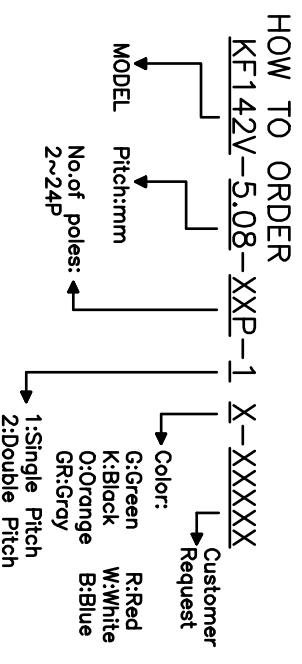

GENERAL TOLERANCE		ANGLE TOLERANCE	
X.	±0.5	X.	±5'
.X	±0.3	.X	±3'
.XX	±0.1	.XX	±1'

DRAWING TYPE	CUSTOMER	SHEET	1 OF 1
SCALE	1:1	SHEET	1 OF 1

DRAWING NO.	XP0012016-xxxx
-------------	----------------

PROJECTION: TITLE: **KF142V-5.08-XXP**

UNITS: mm

SHEET SIZE: A4 SERIES: KF142

凯峰电子有限公司
 CIXI KAIFENG ELECTRONIC CO.,LTD