

REV.	DESCRIPTION	DATE	DRAWN	APPROVED
A1	DWG.REL	2016/10/7	FANG	YANG

- Material  
 ①Pin header : Brass, Tin plated  
 ②Housing : PA66, UL94V-0

- Electrical  
 UL IEC  
 Rated voltage : 300V 250V  
 Rated current : 10A 12A  
 Insulation resistance: 500MΩ/DC500V  
 Withstanding Voltage : AC2000V/1min

- Mechanical  
 Operating temperature: -40℃~+105℃  
 Soldering temperature: 250℃±5/5sec

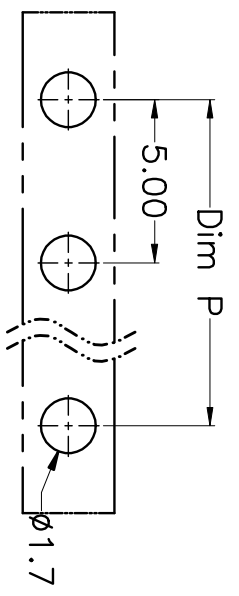
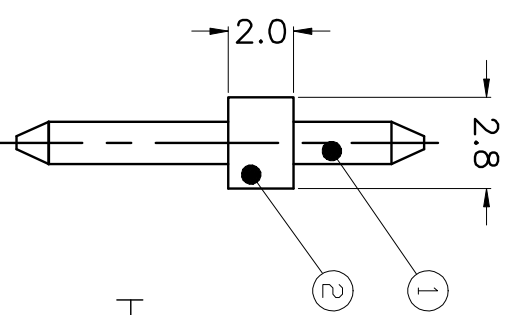
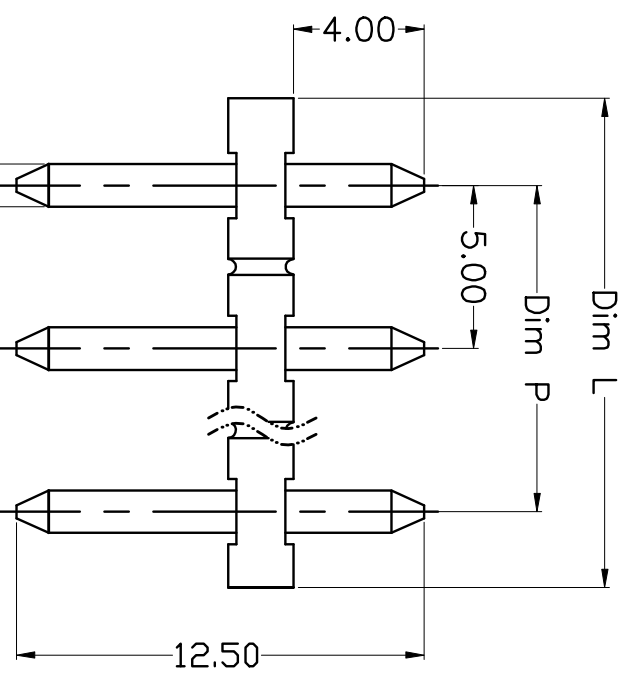

Poles	Dim P	Dim L
2-6P	±0.10	±0.15
7-12P	±0.20	±0.20
13-18P	±0.25	±0.30
19-24P	±0.30	±0.40

N=Number of Poles  
 Dim P=(N-1)×5.00  
 Dim L=N×5.00

GENERAL TOLERANCE ANGLE TOLERANCE

X.	±0.5	X.	±5°
.X	±0.3	.X	±3°
.XX	±0.1	.XX	±1°

DRAWING TYPE	CUSTOMER	SHEET	1 OF 1
SCALE	1:1	SHEET	1 OF 1
DRAWING NO.	XP0012016-xxxx		

### HOW TO ORDER

KF332N-5.0-XXP-1 X-XXXXX

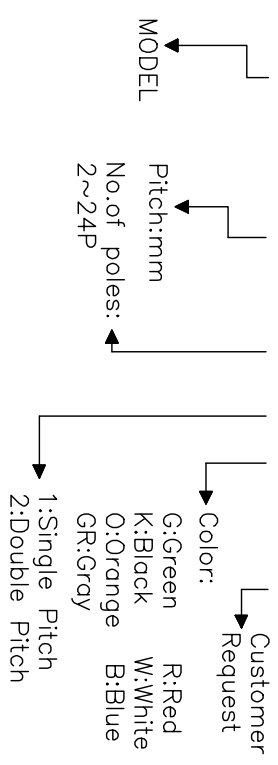

PROJECTION	TITLE
UNITS mm	KF332N-5.0-XXP
SHEET SIZE A4	SERIES KF332N

**KF** 慈溪市凯峰电子有限公司  
 KAIFENG ELECTRONIC CIXI KAIFENG ELECTRONIC CO.,LTD