

REV.	DESCRIPTION	DATE	DRAWN	APPROVED
A1	DWG.REL	2016/10/7	FANG	YANG

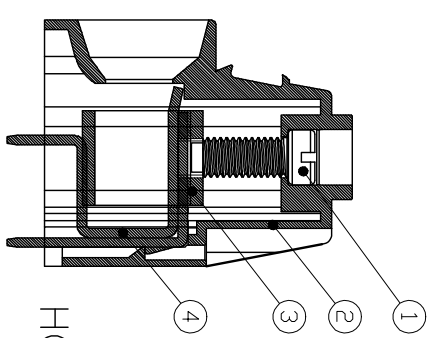
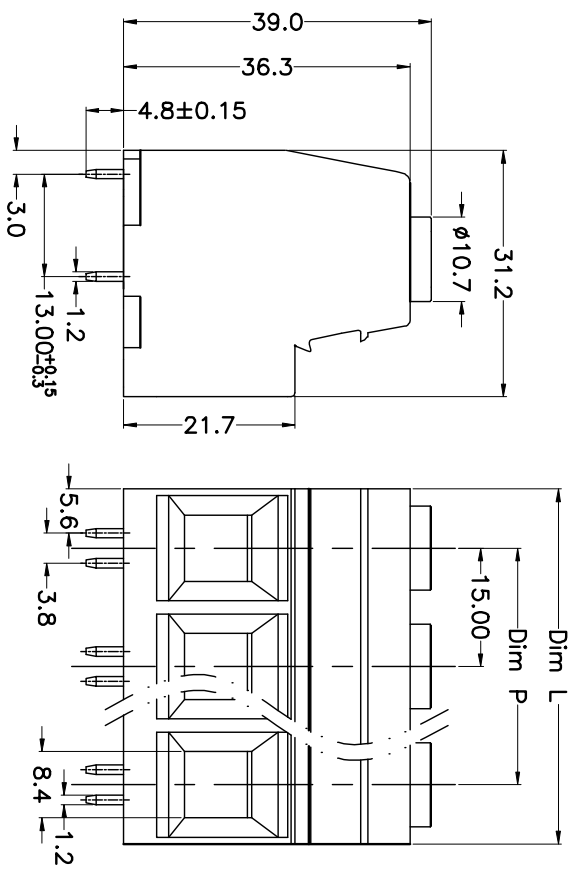
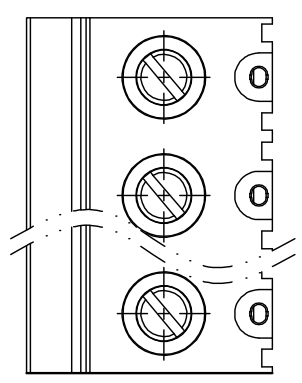

- Material
  - ⊙Screws : M5.0 steel, Zinc plated,
  - “-” slot type
  - ⊙Housing : PA66, UL94V-0
  - ⊙Clamp : Steel, Zinc plated
  - ⊙Pin header : Brass, Tin plated

- Electrical
  - UL IEC
  - Rated voltage : 600V 1000V
  - Rated current : 90A 125A
  - Insulation resistance: 500MΩ/DC500V
  - Withstanding Voltage : AC3500V/1min
  - Wire range: 24-2AWG 25.0mm<sup>2</sup>

- Mechanical
  - Operating temperature: -40°C to +105°C
  - Soldering temperature: 250°C±5/5sec
  - Torque: 2.0N.m (20.40Lb.in)
  - Strip length: 15-17mm

### HOW TO ORDER

KF137-15.0-XXP-1 X-XXXXXX

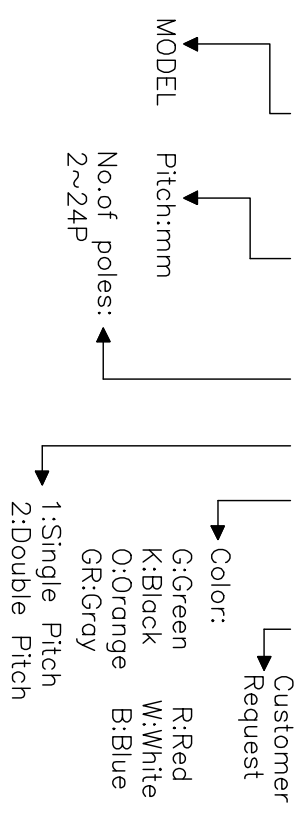

N=Number of Poles  
Dim P=(N-1)x15.00  
Dim L=Nx15.00

Poles	Dim P	Dim L
2-6P	±0.10	±0.15
7-12P	±0.20	±0.20
13-18P	±0.25	±0.30
19-24P	±0.30	±0.40

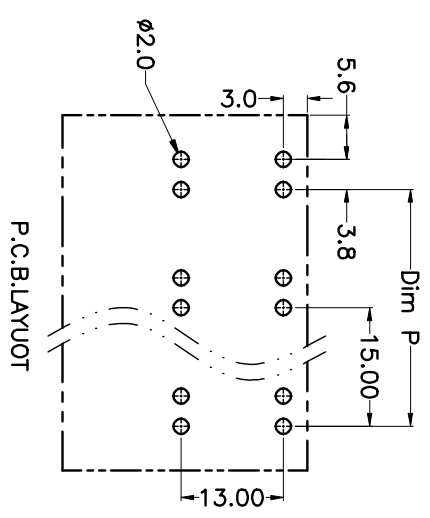

### GENERAL TOLERANCE ANGLE TOLERANCE

X.	±0.5	X.	±5°
.X	±0.3	.X.	±3°
.XX	±0.1	.XX.	±1°

DRAWING TYPE	CUSTOMER	SHEET	1 OF 1
SCALE	1:1		
DRAWING NO.	XP0012016-xxxx		

### PROJECTION TITLE

UNITS	mm	TITLE	KF137-15.0-XXP
SHEET SIZE	A4	SERIES	KF137

**KF 慈溪市凯峰电子有限公司**  
KAIFENG ELECTRONIC CIXI KAIFENG ELECTRONIC CO.,LTD