

REV.	DESCRIPTION	DATE	DRAWN	APPROVED
A1	DWG.REL	2016/10/7	FANG	YANG

- Material
 - ØScrews : M3.0 steel, Zinc plated,
 - “-” slot type
 - ØHousing : PA66, UL94V-0
 - ØClamp : Brass, Ni plated
 - ØPin header : Brass, Tin plated

- Electrical

UL	IEC
Rated voltage : 300V	630V
Rated current : 30A	32A
Insulation resistance: 500MΩ/DC500V	
Withstanding Voltage : AC3000V/1min	
Wire range: 26-10AWG	4.0mm ²

- Mechanical
 - Operating temperature: -40°C~+105°C
 - Soldering temperature: 250°C±5/5sec
 - Torque: 0.5N.m (4.43lb.in)
 - Strip length: 6-7mm

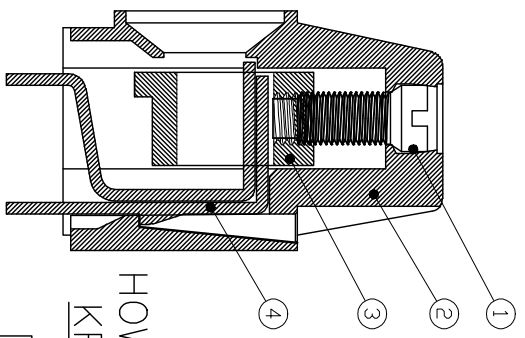

HOW TO ORDER

KF136-10.16-XXP-1 X-XXXXX

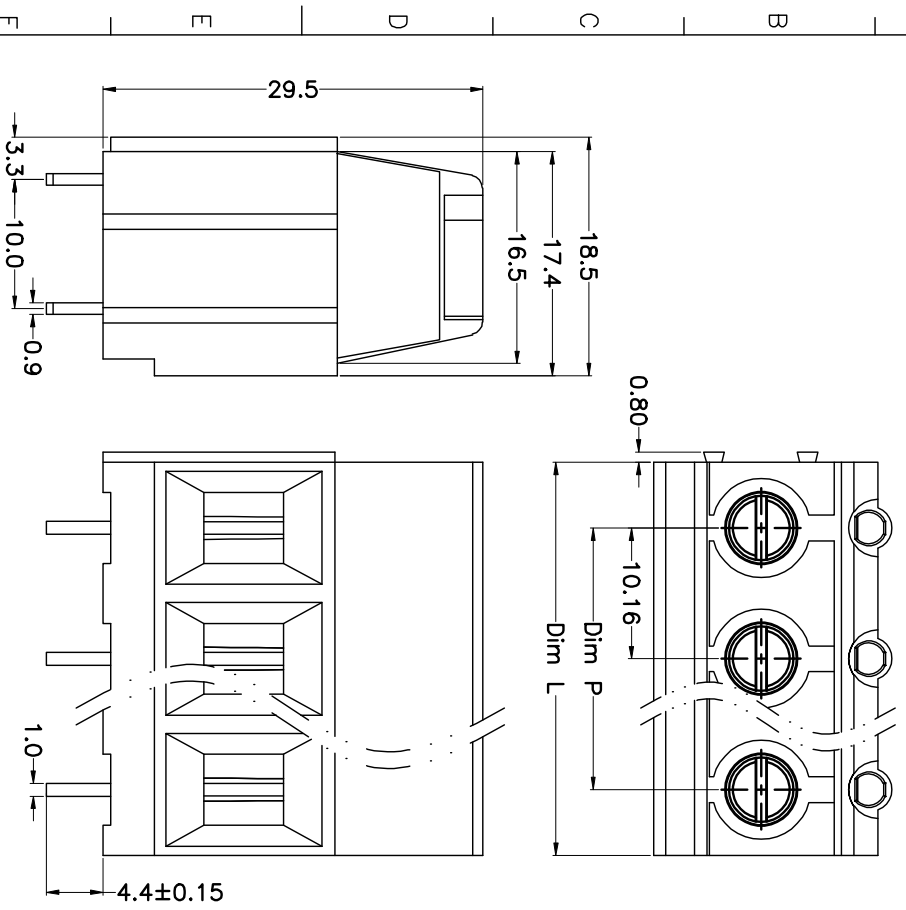
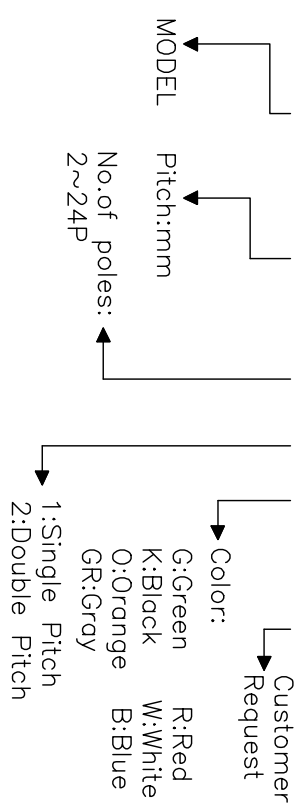

N=Number of Poles
Dim P=(N-1)x10.16
Dim L=Nx10.16

Poles	Dim P	Dim L
2-6P	±0.10	±0.15
7-12P	±0.20	±0.20
13-18P	±0.25	±0.30
19-24P	±0.30	±0.40

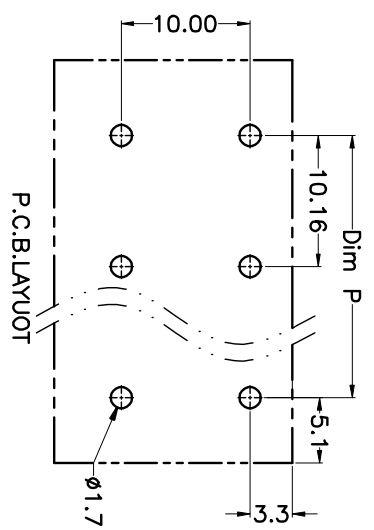

GENERAL TOLERANCE ANGLE TOLERANCE

X.	±0.5	X.	±5°
.X	±0.3	.X	±3°
.XX	±0.1	.XX	±1°

DRAWING TYPE	CUSTOMER	SHEET	1 OF 1
SCALE	1:1	SHEET	1 OF 1
DRAWING NO.	XP0012016-xxxx		

PROJECTION	UNIT	TITLE
mm	mm	KF136-10.16-XXP
SHEET SIZE	A4	SERIES
		KF136

KF 慈溪市凯峰电子有限公司
KAIFENG ELECTRONIC CIXI KAIFENG ELECTRONIC CO.,LTD