

REV.	DESCRIPTION	DATE	DRAWN	APPROVED
A1	DWG.REL	2016/10/7	FANG	YANG

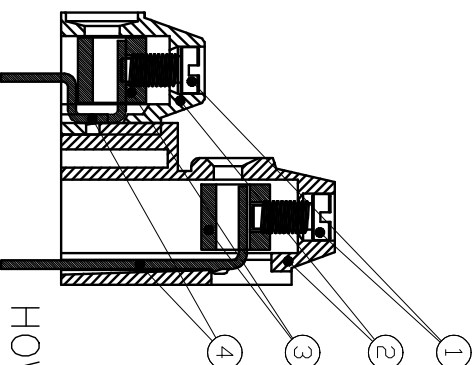
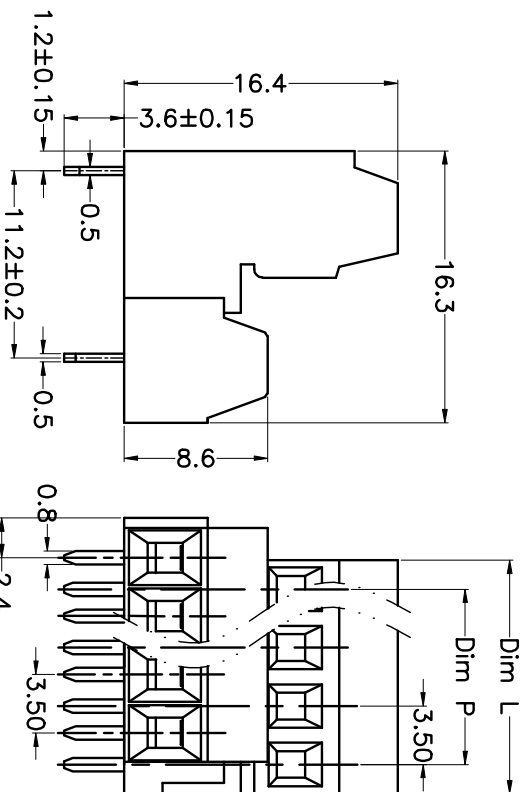
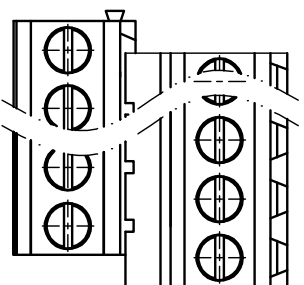

- Material
- Screws : M2.0 steel, Zinc plated, “—” slot type
- Housing : PA66, UL94V-0
- Clamp : Brass, Ni plated
- Pin header : Brass, Tin plated

- Electrical UL IEC
- Rated voltage : 150V 130V
- Rated current : 10A 10A
- Insulation resistance: 500MΩ/DC500V
- Withstanding Voltage : AC1500V/1min
- Wire range: 26-16AWG 1.5mm<sup>2</sup>

- Mechanical
- Operating temperature: -40°C ~ +105°C
- Soldering temperature: 250°C ±5/5sec
- Torque: 0.2N.m (1.77Lb.in)
- Strip length: 5-6mm

### HOW TO ORDER

KF124DGB-3.5-XXP-1 X-XXXXX

N=Number of Poles  
Dim P=(N-1)x3.50  
Dim L=Nx3.50

Poles	Dim P	Dim L
2-6P	±0.10	±0.15
7-12P	±0.20	±0.20
13-18P	±0.25	±0.30
19-24P	±0.30	±0.40

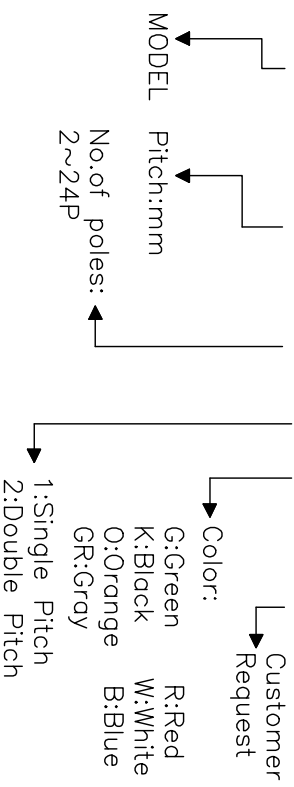

### GENERAL TOLERANCE ANGLE TOLERANCE

X. ±0.5	X. ±5'
.X ±0.3	.X ±3'
.XX ±0.1	.XX ±1'

PROJECTION	TITLE
UNITS mm	KF124DGB-3.5-XXP
SHEET SIZE A4	SERIES KF124DGB

DRAWING TYPE CUSTOMER	SCALE 1:1	SHEET 1 OF 1
DRAWING NO. XP0012016-xxxx		

**KF 慈溪市凯峰电子有限公司**  
KAIFENG ELECTRONIC CIXI KAIFENG ELECTRONIC CO.,LTD