

REV.	DESCRIPTION	DATE	DRAWN	APPROVED
A1	DWG.REL	2016/10/7	FANG	YANG

- Material
  - ⊙Screws : M1.6 steel, Zinc plated,
  - “-” slot type
  - ⊙Housing : PA66, UL94V-0
  - ⊙Clamp : Brass, Ni plated
  - ⊙Pin header : Brass, Tin plated

- Electrical
  - UL IEC
  - Rated voltage : 150V 13V
  - Rated current : 6A 8A
  - Insulation resistance: 500MΩ/DC500V
  - Withstanding Voltage : AC1500V/1min
  - Wire range: 26-18AWG 1.0mm<sup>2</sup>

- Mechanical
  - Operating temperature: -40°C to +105°C
  - Soldering temperature: 250°C±5/5sec
  - Torque: 0.1N.m (0.89Lb.in)
  - Strip length: 3.7-4.7mm

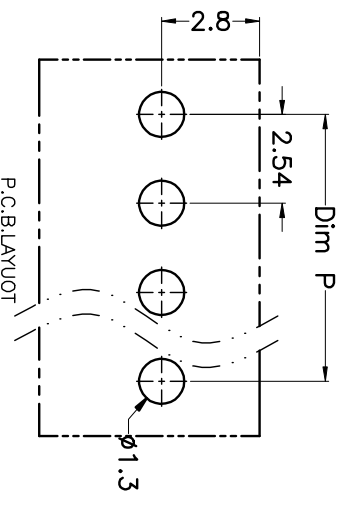
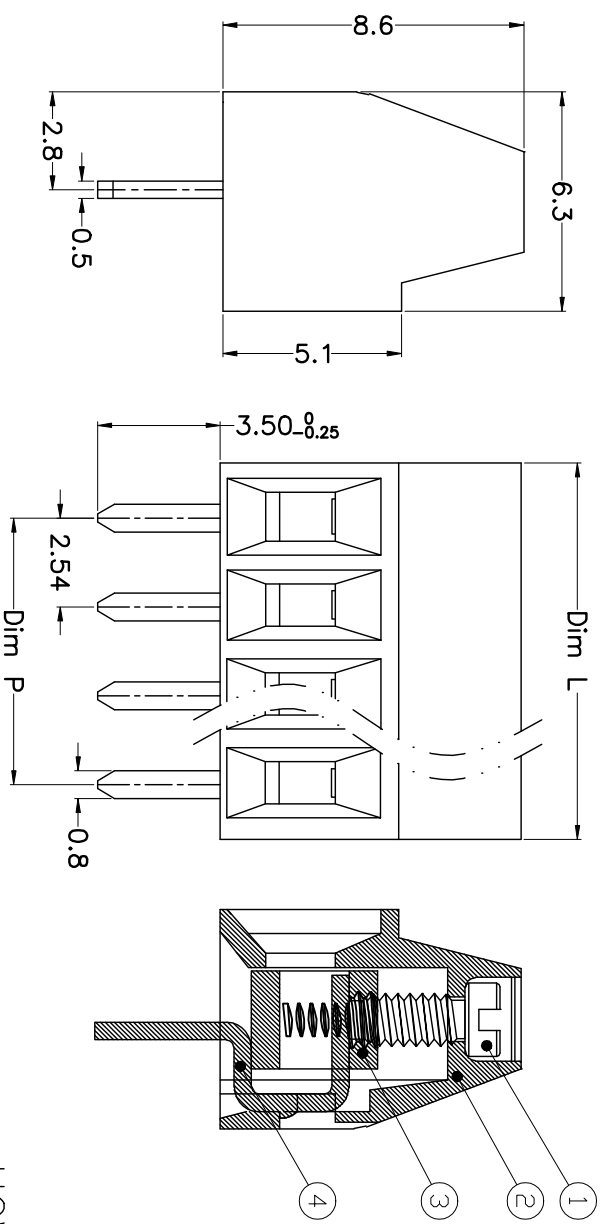

N=Number of Poles  
Dim P=(N-1)X2.54  
Dim L=Nx2.54+0.6

Poles	Dim P	Dim L
2-6P	±0.10	±0.15
7-12P	±0.20	±0.20
13-18P	±0.25	±0.30
19-24P	±0.30	±0.40

GENERAL TOLERANCE		ANGLE TOLERANCE	
X.	±0.5	X.	±5'
.X	±0.3	.X'	±3'
.XX	±0.1	.XX'	±1'
DRAWING TYPE	CUSTOMER	SHEET	1 OF 1
SCALE	1:1		
DRAWING NO.	XP0012016-xxxx		

### HOW TO ORDER

KF120-2.54-XXP-1 X-XXXXX

MODEL Pitch:mm No.of poles: 2~24P

Color: G:Green K:Black O:Orange GR:Gray R:Red W:White B:Blue

Customer Request 1:Single Pitch 2:Double Pitch

PROJECTION: TITLE: KF120-2.54-XXP

UNITS: mm

SHEET SIZE: A4 SERIES: KF120

**KF 慈溪市凯峰电子有限公司**  
KAIFENG ELECTRONIC CIXI KAIFENG ELECTRONIC CO.,LTD